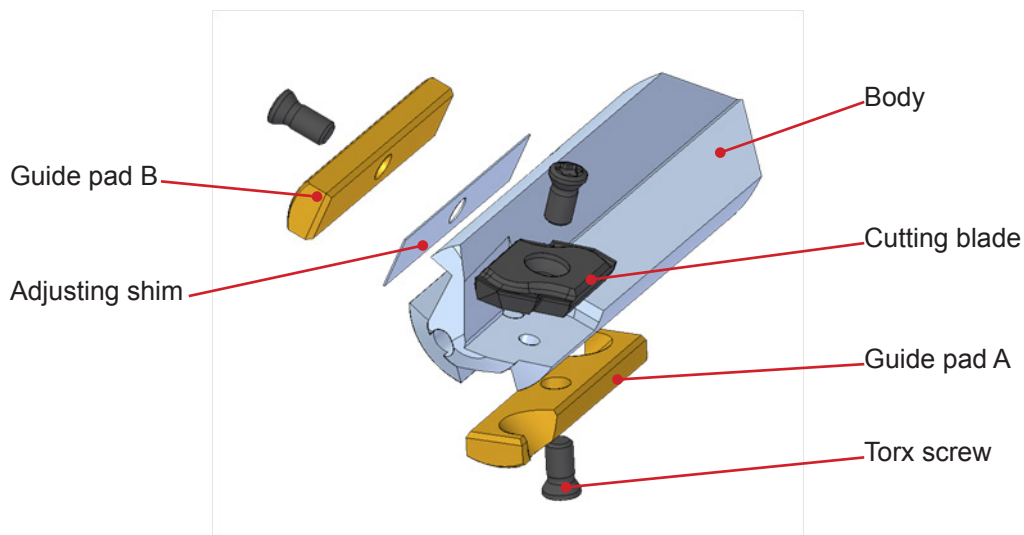

Type 120 Single Lip drills with indexable inserts**1. Main Features**

- High efficiency by specifically developed cutting edge geometry for optimal chip formation.
- Short downtime resulting from quick exchange of wear parts on the clamped tool.
- Easy to use, no sharpening, no length adjustment, easy inventory of wear parts.
- Long tool life due to full coating and edge treatment
- Quick availability due to stocked wear parts.

2. Design**3. Technical Information**

- Current diameter range: 12.00 mm – 28.00 mm
- Cutting blade & guide pads fully coated
- Covering the whole diameter range with only 6 sizes of cutting blades.
- Tool body built in steps of 0.1 mm
- Available with long head and three additional guide pads.
- Adjusting shim ranging from 0.1 to 0.2 mm in steps of 0.02 mm

4. Inquiries and delivery

- Please state the required diameter, the overall length and the clamping element.
- You will receive your tools fully equipped and ready for use.
- Each tool comes with the suitable Torx key for the replacement of wearing parts

